

Features

- 24 GHz short range transceiver
- 90 MHz sweep FM input
- High sensitivity, with integrated RF/IF amplifier
- Dual 30 patch antenna
- Buffered, gain adjustable I/Q IF outputs
- Additional DC IF outputs
- Beam aperture 25°/12°
- RSW Rapid Sleep Wakeup
- Slim 6mm thickness construction

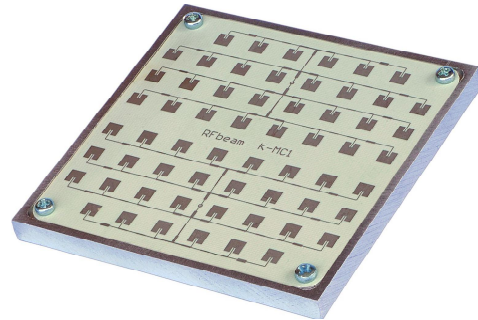

Applications

- Traffic supervision
- Object speed measurement systems
- Ranging and distance detection
- Industrial sensors

Description

K-MC1 is a 60 patch doppler module with an asymmetrical narrow beam for long distance sensors. It is ideally suited for traffic supervision.

This module includes a RF low noise amplifier and two 54dB IF preamplifiers for both I and Q channels. The need for external analogue electronics will be significantly reduced by this feature. For special signal condition applications, an additional buffered Mixer DC output is provided. This greatly improves flexibility in FSK ranging applications.

The unique "RSW" Rapid Sleep Wakeup function with <math><7\mu\text{s}</math> wakeup time makes this module ideal for battery operated equipment. Typical duty cycle in RWS mode may be <math><1\%</math> with full movement detection capability by sampling the IF signals.

An extremely slim construction with only 6mm depth gives you maximum flexibility in your equipment design.

A powerful starterkit with signal conditioning and visualization is also available.

Blockdiagram

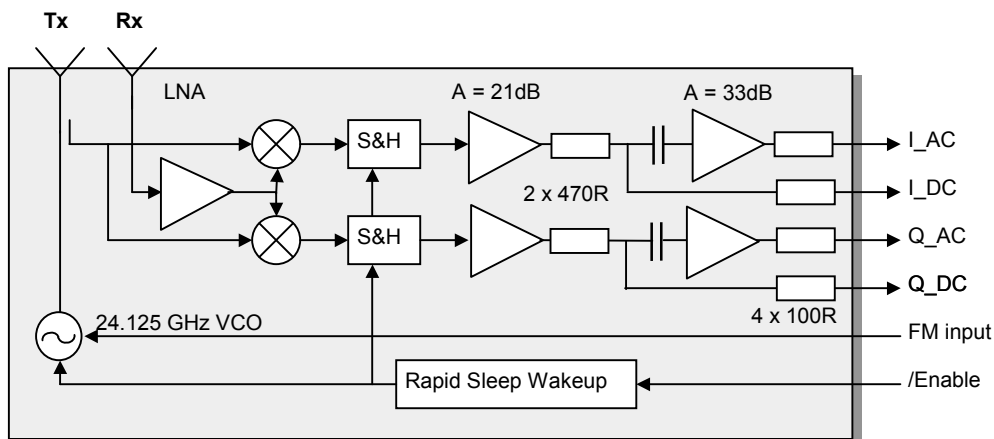

Fig. 1: K-MC1 Blockdiagram

Characteristics

Parameter	Conditions / Notes	Symbol	Min	Typ	Max	Unit
Operating conditions						
Supply voltage		V_{CC}	4.75	5.0	5.25	V
Supply current	Module enabled (Pin 1 = V_{IL})	I_{CC}		80	100	mA
	Module RSW mode (Pin 1 = V_{IH})			5	7	mA
VCO input voltage		U_{VCO}	0		5.0	V
VCO pin resistance	Internal pulldown 10k	R_{VCO}		10k		Ω
Operating temperature		T_{op}	-20		+80	$^{\circ}C$
Storage temperature		T_{st}	-20		+80	$^{\circ}C$
Power down/Enable						
Module power down	Input tied high with pullup 10k	V_{IH}	$V_{CC}-0.7$		$V_{CC}+0.3$	V
Module enable		V_{IL}	-0.2		2	V
Minimum enable time	Sample&Hold capacitor charged	t_{on}	7			μs
Maximum hold time	S&H error <10%	t_{off}			2	ms
Transmitter						
Transmitter frequency	$U_{VCO}=2V, T_{amb}=-20^{\circ}C \dots +60^{\circ}C$	f_{TX}	24.050	24.150	24.250	GHz
Frequency drift vs temp.	$V_{CC}=5.0V, -20^{\circ}C \dots +60^{\circ}C$ ^{Note 1}	Δf_{TX}		-1.0		MHz/ $^{\circ}C$
Frequency tuning range		Δf_{VCO}	81	89		MHz
VCO sensitivity		S_{VCO}		22		MHz/V
VCO Modulation Bandwidth	$\Delta f=20MHz$	B_{VCO}		3		MHz
Output power	EIRP	P_{TX}	+16	+18	+20	dBm
Output power deviation	Full VCO tuning range	ΔP_{TX}			+/- 1	dBm
Spurious emission	According to ETSI 300 440	P_{spur}			-30	dBm
Receiver						
Antenna gain	$F_{TX}=24.125GHz$ ^{Note 2}	G_{Ant}		18.5		dBi
LNA gain	$F_{RX}=24.125GHz$	G_{LNA}		16		dB
Mixer Conversion loss	$f_{IF}=500Hz$	D_{mixer}		-6		dB
Receiver sensitivity	$f_{IF}=500Hz, B=1kHz, S/N=6dB$	P_{RX}		-123		dBm
Overall sensitivity	$f_{IF}=500Hz, B=1kHz, S/N=6dB$	D_{system}		-141		dBc
IF output						
IF output impedance	_AC outputs	R_{IF_AC}		100		Ω
	DC outputs	R{IF_DC}		570		Ω
IF Amplifier gain	_AC outputs	G_{IF_AC}		54		dB
	DC outputs	G{IF_DC}		21		dB
I/Q amplitude balance	$f_{IF}=500Hz, U_{IF}=100mV_{pp}$ (_AC outputs)	ΔU_{IF}		3		dB
I/Q phase shift	$f_{IF}=500Hz, U_{IF}=100mV_{pp}$ (_AC outputs)	φ	80	90	100	$^{\circ}$
IF frequency range	-3dB Bandwidth (_AC outputs)	f_{IF_AC}	40		15k	Hz
	-3dB Bandwidth (_DC outputs)	f_{IF_DC}	0		300	kHz

K-MC1 RADAR TRANSCEIVER

Datasheet

Parameter	Conditions / Notes	Symbol	Min	Typ	Max	Unit
IF output (continued)						
IF noise voltage	$f_{IF} = 500\text{Hz}$	$U_{IFnoise}$		22		$\mu\text{V}/\sqrt{\text{Hz}}$
	$f_{IF} = 500\text{Hz}$	$U_{IFnoise}$		-93		dBV/Hz
IF output offset voltage	$V_{CC} = 5\text{V}$, _AC outputs	U_{OS_AC}	2.0	2.5	3.0	V
	no object in range, VCO pin open, _DC outputs	U_{OS_DC}	0.5	2.5	4.5	V
Supply rejection	Rejection supply pins to _AC outputs, 500Hz	D_{supply}		-24		dB
Antenna						
Horizontal -3dB beamwidth	E-Plane	W_{θ}		12		$^{\circ}$
Vertical -3dB beamwidth	H-Plane	W_{θ}		25		$^{\circ}$
Horiz. sidelobe suppression		D_{θ}		-20		dB
Vert. sidelobe suppression		D_{θ}		-18		dB
Body						
Outline Dimensions	connector left unconnected			65*65*6		mm^3
Weight				50		g
Connector	Module side: AMP X-338069-8			8		pins

Note 1 Transmit frequency stays within 24.050 to 24.250GHz over the specified temperature range when the VCO pin is left open

Note 2 Theoretical value, given by Design

Antenna System Diagram

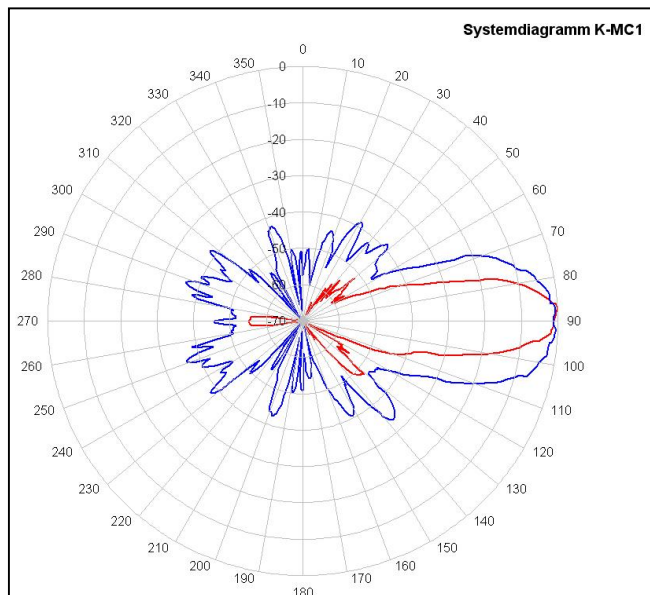

Fig. 2: Antenna system diagram

This diagram shows module sensitivity in both azimuth and elevation directions. It incorporates therefore the transmitter and receiver antenna characteristics.

FM Characteristics

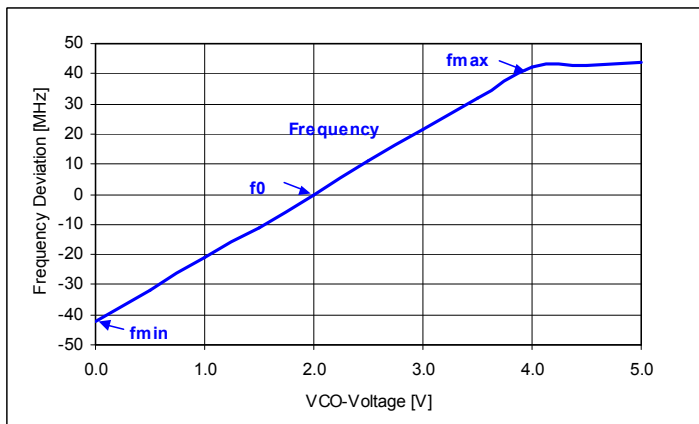

Fig. 3: Typical Frequency vs. VCO voltage

Pin Configuration

Pin	Description	Typical Value
1	/Enable	GND: module active
2	VCC	5V supply
3	GND	0V supply
4	IF output Q_AC	high gain output
5	IF output I_AC	high gain output
6	VCO in	2.0V = f_0
7	IF output I_DC	low gain output
8	IF output Q_DC	Low gain output

Outline Dimensions

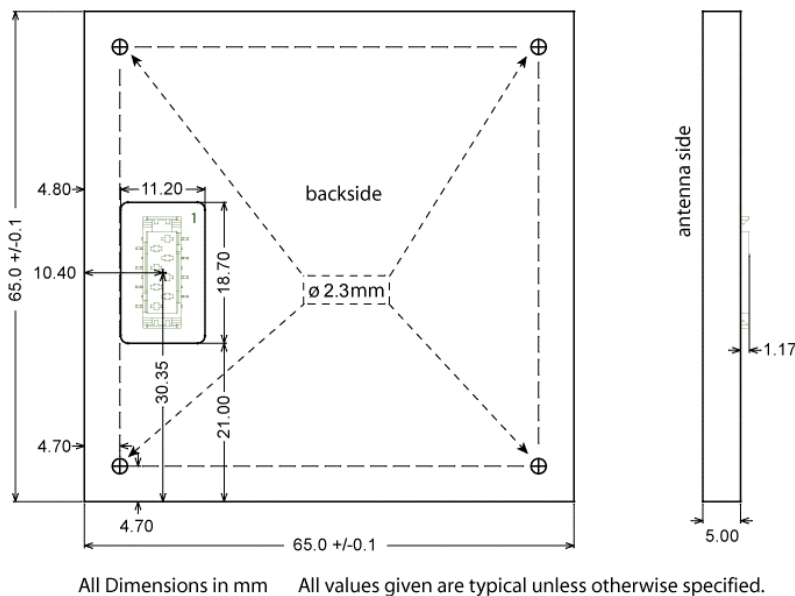

Fig. 4: Mechanical dimensions

Mounting instruction

K-MC1 modules must not be used without screws.

The antenna PCB is glued into the case against damage, but not for practical use of the module.

Original screws may be unscrewed and replaced by M2 screws for fixation on a holder.

The module may also be pressed onto the backside of a plate with an aperture for the antenna and screws.

Application Notes

Using VCO and Internal IF Amplifier

The IF amplifier provides two outputs per channel according to Fig. 1. These outputs are designed for different requirements in processing radar signals. Both I (imaginary) and Q (real) mixer signals are available. The I and Q signals are phase shifted by $+90^\circ$ or -90° , depending on the moving direction of objects in range.

FMCW generates an output signal even without an object in range because of the finite isolation between transmitter and receiver path. This effect is called self-mixing and leads to a DC signal that depends on the carrier frequency. Using FMCW, these signals move and may overdrive the 2nd stage (x_AC outputs) of the IF amp under certain circumstances.

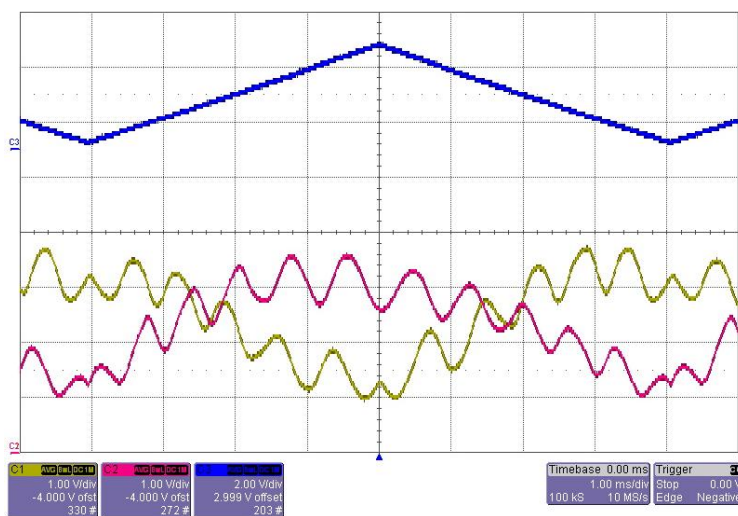

Triangle VCO Voltage with $A=3.8V_{pp}$ and $f=125Hz$. Resulting transmit frequency deviation of 120MHz approx.

I_AC and Q_AC outputs show a low frequency caused by local carrier feedthrough.

The superposed higher frequency with 1.25kHz is caused by a target.

The peak-peak amplitude of 2.8Vpp is no problem, because the x_AC outputs are limited at 4.5Vpp approx.

Fig. 5: x_AC Output FMCW signals with triangle VCO and $df = 120MHz$

I_AC and Q_AC High Gain Outputs

These outputs provide high gain/low noise signals generated by doppler effects or FMCW. They directly can drive ADC input stages of microprocessors or DSPs. Even with 10Bit of resolution only, sensitive and relatively long range Doppler detections are possible. The outputs cover a frequency range of 40Hz ... 15kHz.

However, these outputs may saturate and clip because of too high input signals. In these cases you may use the x_DC outputs described below.

There is also a possibility to adjust output levels by using a resistor at the x_DC outputs. (see chapter Adjusting IF Gain).

I_DC and Q_DC Low Gain Outputs

The low gain DC outputs (I_DC and Q_DC) hardly enter into a saturation state and may be used in cases, where the high gain outputs (I_AC and Q_AC) are clipped because of high input signals. Saturation and clipping typically arise in conjunction with FMCW and may be caused by objects nearby the sensor, non-compensated radoms etc.

These outputs carry more signal information than the x_AC outputs because of their bandwidth ranging from DC to 300kHz. Using ADCs with resolutions of 12Bits and more and processing with DSP processors allow versatile and flexible radar applications.

Adjusting IF Gain

If there is a risk of overdriving the 2nd amplifier, you may use the low gain x_DC outputs or attenuate the input signals of the 2nd stage amp.

Gain of the 2nd stage amplifier may be lowered by adding an external resistor at pins I_DC and Q_DC connected to GND. Please refer to Fig. 1: K-MC1 Blockdiagram to understand the resistive attenuator.

2nd stage gain A_R may be adjusted between 18dB and 33dB resp. attenuated by max. 15dB.

Without additional Resistor:	$A_R = 33\text{dB} = 45$	resulting total IF gain: 54dB = 500
With short circuit at x_DC to ground	$A_R = 18\text{dB} = 8$	resulting total IF gain: 39dB = 89

$$A_R = 45 / \left(1 + \frac{470}{100 + R_x}\right) \quad \text{or} \quad R_x = \frac{470}{(45 / A_R) - 1} - 100$$

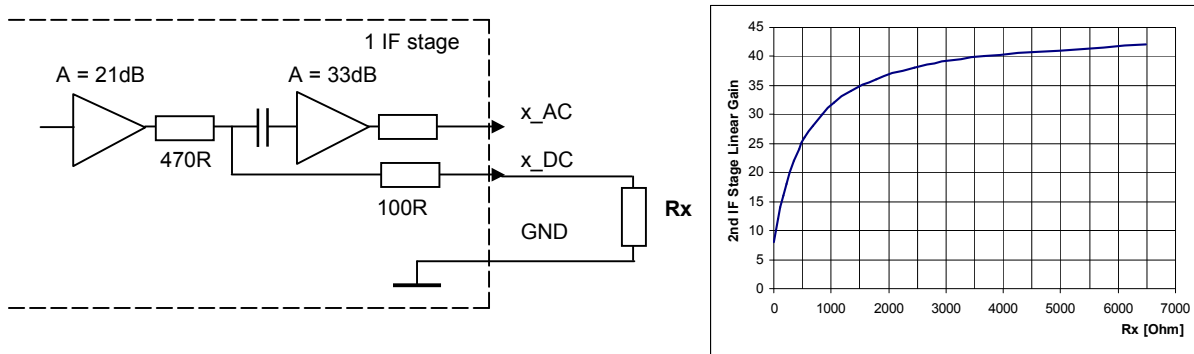

Fig. 6: Attenuating xAC outputs via x_DC pins

Rapid Sleep Wakeup (RSW)

RFbeam's unique rapid sleep wakeup feature allows power savings of more than 90% during 'silent' periods. The module may be used in a relaxed sampling mode as long as no movements are detected. RSW also helps saving power, if not the full IF bandwidth of 15kHz is needed.

In battery operated equipment such as traffic control, RSW may significantly lower battery and equipment volume and cost.

RSW in Action

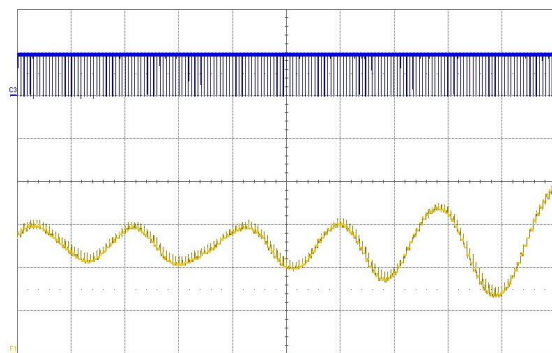

Fig. 7: Sampled Doppler signal at x_AC outputs

This graph shows the sampling signal at pin $/Enable$ and a resulting output signal at an x_AC pin caused by an approaching object.

This signal may be processed 'as is' or used as trigger to start continuous acquisition.

If RSW mode is used only to detect any movement, aliasing effects are not important (i.e. undersampling is useful).

By choosing a sampling frequency, aliasing must be taken into account, if frequency measurements are intended.

RSW principle

RSW combines switching of the RF oscillator and sample&hold of the mixer signals (please refer to Fig. 1: K-MC1 Blockdiagram). During sleep mode (pin /ENABLE = high), only the amplifiers stay switched on to hold the output voltage and coupling capacitor charges. This assures minimum peaks at the outputs when returning to the active state.

Nevertheless, we have to take some important effects into account. An important effect is charge injection, caused by the digital control signal.

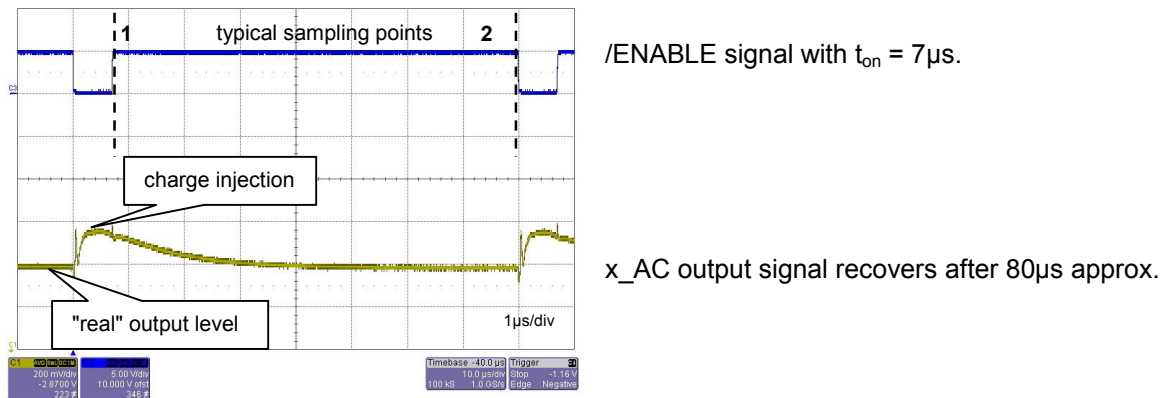

Fig. 8: x_AC output is influenced by charge injection caused by switching signal

Sampling sequence

To simplify signal processing sequence, output sampling may be done immediately after /ENABLE goes high (1) or before next /ENABLE (2).

Both methods have their advantages and disadvantages:

- Sampling point (1) contains a constant overshoot, i.e. sampled output signal becomes shifted by a constant DC component. There is no loss of sensitivity.
- Sampling point (2) corresponds to the real mixer output, as long as sleep time is short enough. But with longer off times, signal amplitude decreases.

As a rule of thumb: with a repeat frequency of 1kHz (duty cycle of $7\mu s/1ms = 0.7\%$) amplitude loss is 3dB approx. This situation is shown in the figure below.

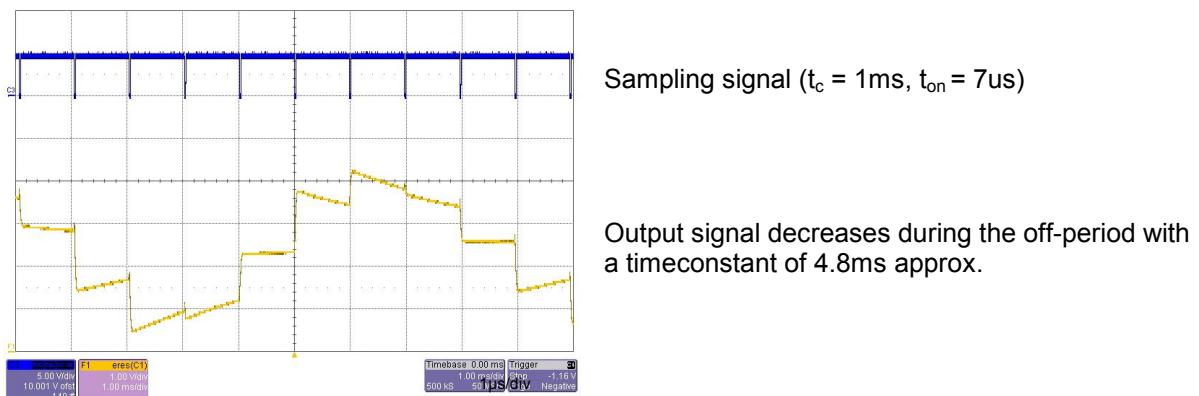

Fig. 9: x_AC output amplitude decreases during sleep time.

Sensitivity and Maximum Range

The values indicated here are intended to give you a 'feeling' of the attainable detection range with this module. It is not possible to define an exact RCS (radar cross section) value of real objects because reflectivity depends on many parameters. The RCS variations however influence the maximum range only by $\sqrt[4]{\sigma}$.

Maximum range for Doppler movement depends mainly on:

- | | | |
|--|-------------------|---|
| - Module sensitivity | S: | -141dBc (@1kHz IF Bandwidth) |
| - Carrier frequency | f ₀ : | 24.125GHz |
| - Radar cross section RCS ("reflectivity") of the object | σ ¹⁾ : | 1m ² approx. for a moving person
>50m ² for a moving car |

note ¹⁾ RCS indications are very inaccurate and may vary by factors of 10 and more.

The famous "Radar Equation" may be reduced for our K-band module to the following relation:

$$r = 0.0167 \cdot 10^{\frac{-s}{40}} \cdot \sqrt[4]{\sigma}$$

Using this formula, you get an indicative detection range of

- 56 meters for a moving person
- > 150 meters for a moving car

Please note, that range values also highly depend on the performance of signal processing, environment conditions (i.e. rain, fog), housing of the module and other factors.

Datasheet Revision History

Version	Date	Changes
1.0	08-Aug-2007	initial release
1.1	29-Oct-2008	Replaced Fig. 4: Mechanical dimensions Added chapter Mounting instruction
1.2	09-Nov-2009	Operating temperature corrected to +80°C
1.3	15-Dec-2009	VCO sensitivity corrected to 22MHz/V

RFbeam does not assume any responsibility for use of any circuitry described, no circuit patent licenses are implied and RFbeam reserves the right at any time without notice to change said circuitry and specifications.