

## Features

- 24 GHz short range transceiver
- 180 MHz sweep FM input
- High sensitivity, with integrated RF/IF amplifier
- Dual 30 patch antenna
- Buffered I/Q IF outputs
- Additional DC IF outputs
- Beam aperture 25°/12°
- RSW Rapid Sleep Wakeup
- Slim 6mm thickness construction

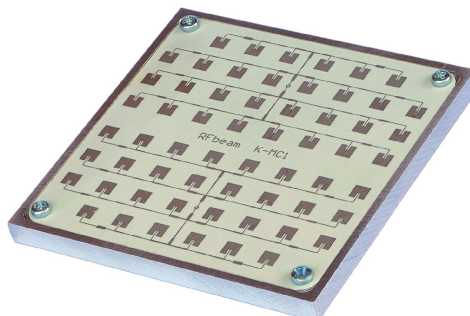

## Applications

- Traffic supervision
- Object speed measurement systems
- Ranging and distance detection
- Industrial sensors

## Description

K-MC1 is a 60 patch doppler module with an asymmetrical narrow beam for long distance sensors. It is ideally suited for traffic supervision.

This module includes a RF low noise amplifier and two 47dB IF preamplifiers for both I and Q channels. The need for external analogue electronics will be significantly reduced by this feature. For special signal condition applications, an additional buffered Mixer DC output is provided. This greatly improves flexibility in FSK ranging applications.

The unique "RSW" Rapid Sleep Wakeup function with <4us wakeup time makes this module ideal for battery operated equipment. Typical duty cycle in RWS mode may be < 1% with full movement detection capability by sampling the IF signals.

An extremely slim construction with only 6mm depth gives you maximum flexibility in your equipment design.

Powerful starter kits with signal conditioning and visualization are available.

## Blockdiagram

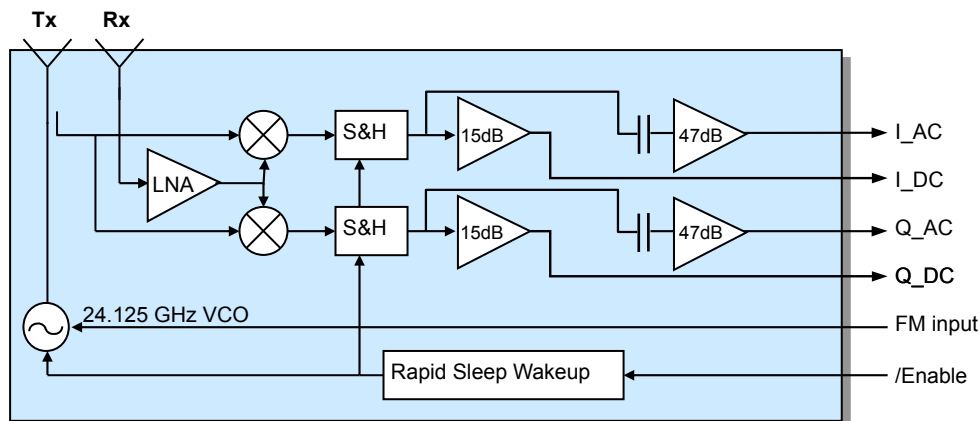

Fig. 1: K-MC1 Blockdiagram

## K-MC1 RADAR TRANSCEIVER

## Datasheet

## Characteristics

Parameter	Conditions / Notes	Symbol	Min	Typ	Max	Unit
<b>Operating conditions</b>						
Supply voltage		$V_{cc}$	4.75	5.0	5.25	V
Supply current	Module enabled (Pin 1 = $V_{IL}$ )	$I_{cc}$		70	100	mA
	Module RSW mode (Pin 1 = $V_{IH}$ )			7	10	mA
VCO input voltage		$U_{VCO}$	1		10	V
VCO pin resistance	Internal pulldown 10k	$R_{VCO}$		10k		$\Omega$
Operating temperature		$T_{op}$	-20		+80	$^{\circ}C$
Storage temperature		$T_{st}$	-20		+80	$^{\circ}C$
<b>Power down/Enable</b>						
Module power down	Input tied high with pullup 10k	$V_{IH}$	$V_{cc}-0.7$		$V_{cc}+0.3$	V
Module enable		$V_{IL}$	-0.2		2	V
Minimum enable time	Sample&Hold capacitor charged	$t_{on}$	4			$\mu s$
Maximum hold time	S&H error <10%	$t_{off}$			2	ms
Hold Step	Charge injection visible at DC output	$V_{step}$		6		mV
<b>Transmitter</b>						
Transmitter frequency	$U_{VCO}=5V, T_{amb}=-20^{\circ}C \dots +60^{\circ}C$	$f_{TX}$	24.050	24.150	24.250	GHz
Frequency drift vs temp.	$V_{cc}=5.0V, -20^{\circ}C \dots +60^{\circ}C$ <small>Note 1</small>	$\Delta f_{TX}$		-1.0		MHz/ $^{\circ}C$
Frequency tuning range		$\Delta f_{VCO}$		180		MHz
VCO sensitivity		$S_{VCO}$		18		MHz/V
VCO Modulation Bandwidth	$\Delta f=20MHz$	$B_{VCO}$		3		MHz
Output power	EIRP	$P_{TX}$	+16	+18	+20	dBm
Output power deviation	Full VCO tuning range	$\Delta P_{TX}$		+/- 1		dBm
Spurious emission	According to ETSI 300 440	$P_{spur}$			-30	dBm
<b>Receiver</b>						
Antenna gain	$F_{TX}=24.125GHz$ <small>Note 2</small>	$G_{Ant}$		18.5		dBi
LNA gain	$F_{RX}=24.125GHz$	$G_{LNA}$		16		dB
Mixer Conversion loss	$f_{IF}=500Hz$	$D_{mixer}$		-6		dB
Receiver sensitivity	$f_{IF}=500Hz, B=1kHz, S/N=6dB$	$P_{RX}$		-123		dBm
Overall sensitivity	$f_{IF}=500Hz, B=1kHz, S/N=6dB$	$D_{system}$		-141		dBc
<b>IF output</b>						
IF output impedance	AC outputs	$R_{IF\_AC}$		100		$\Omega$
	DC outputs	$R_{IF\_DC}$		100		$\Omega$
IF Amplifier gain	AC outputs	$G_{IF\_AC}$		47		dB
	DC outputs	$G_{IF\_DC}$		15		dB
I/Q amplitude balance	$f_{IF}=500Hz, U_{IF}=100mV_{pp}$ ( AC outputs)	$\Delta U_{IF}$		3		dB
I/Q phase shift	$f_{IF}=500Hz, U_{IF}=100mV_{pp}$ ( AC outputs)	$\phi$	80	90	100	$^{\circ}$
IF frequency range	-3dB Bandwidth ( AC outputs)	$f_{IF\_AC}$	40		15k	Hz
	-3dB Bandwidth ( DC outputs)	$f_{IF\_DC}$	0		500	kHz
Spurious signals	Internal regulator @100kHz at DC output	$V_{sp}$			0.1	mVrms

## K-MC1 RADAR TRANSCEIVER

## Datasheet

Parameter	Conditions / Notes	Symbol	Min	Typ	Max	Unit
<b>IF output (continued)</b>						
IF noise voltage	$f_{IF} = 500\text{Hz}$	$U_{IFnoise}$		22		$\mu\text{V}/\sqrt{\text{Hz}}$
	$f_{IF} = 500\text{Hz}$	$U_{IFnoise}$		-93		$\text{dBV}/\text{Hz}$
IF output offset voltage	$V_{CC} = 5\text{V}$ , AC outputs	$U_{os\_AC}$	2.0	2.5	3.0	V
	no object in range, VCO pin open, DC outputs	$U_{os\_DC}$	0.5	2.5	4.5	V
Supply rejection	Rejection supply pins to AC outputs, 500Hz	$D_{supply}$		-24		dB
<b>Antenna</b>						
Horizontal -3dB beamwidth	E-Plane	$W_{\theta}$		12		$^{\circ}$
Vertical -3dB beamwidth	H-Plane	$W_{\theta}$		25		$^{\circ}$
Horiz. sidelobe suppression		$D_{\theta}$		-20		dB
Vert. sidelobe suppression		$D_{\theta}$		-18		dB
<b>Body</b>						
Outline Dimensions	connector left unconnected			65*65*6		$\text{mm}^3$
Weight				50		g
Connector	Module side: AMP X-338069-8			8		pins

Note 1 Transmit frequency stays within 24.050 to 24.250GHz over the specified temperature range when the VCO pin is left open

Note 2 Theoretical value, given by Design

## Antenna System Diagram

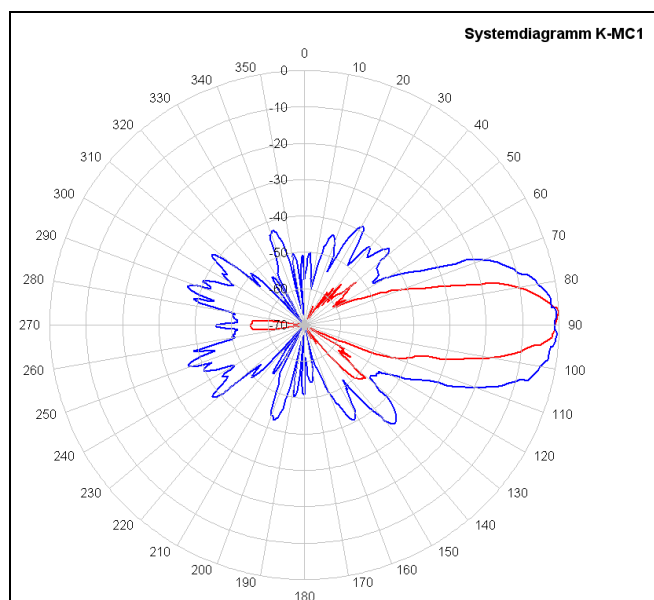

Fig. 2: Antenna system diagram

This diagram shows module sensitivity in both azimuth and elevation directions. It incorporates therefore the transmitter and receiver antenna characteristics.

**FM Characteristics**

Carrier frequency can be modulated by means of a voltage applied to the VCO input. This feature can be used for ranging applications using FMCW ( see also Fig. 4) or FSK techniques.

FMCW needs good linearity in the frequency ramp. RFbeam provides a downloadable tool "VCO-Lin" that allows calculating the non-linearity using 3 known frequency versus VCO voltage points.

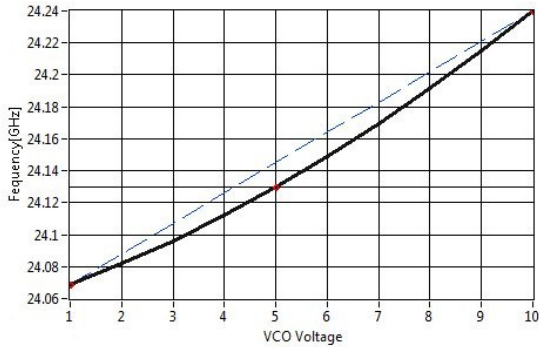
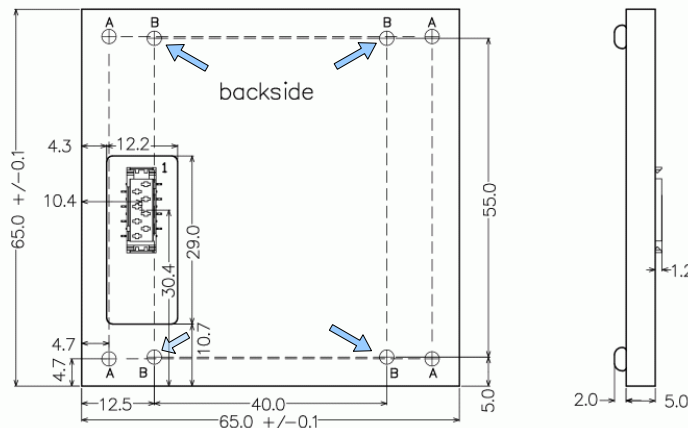

**Fig. 3: Typical carrier frequency vs. VCO voltage**

**Pin Configuration**

Pin	Description	Typical Value
1	/Enable	GND: module active
2	VCC	5V supply
3	GND	0V supply
4	IF output Q AC	high gain output
5	IF output I AC	high gain output
6	VCO in	2.0V = $f_0$
7	IF output I DC	low gain output
8	IF output Q DC	Low gain output

**Outline Dimensions**



**Fig. 4: Mechanical dimensions**

**Mounting instruction**

Mount from back side using thread marked with **B**:  
M2.5 screws, screw depth < 3.5mm

**Alternate mounting:**

Original screws **A** may be unscrewed and replaced by M2 screws for fixation on a holder. **K-MC1 modules must not be used without screws in A.**  
The antenna PCB is glued into the case against damage, but not for practical use of the module.

Antenna side

## Application Notes

### Using VCO and Internal IF Amplifier

The IF amplifier provides two outputs per channel according to Fig. 1. These outputs are designed for different requirements in processing radar signals. Both I (In Phase) and Q (Quadrature) mixer signals are available. The I and Q signals are phase shifted by  $+90^\circ$  or  $-90^\circ$ , depending on the moving direction of objects in range.

FMCW generates an output signal even without an object in range because of the finite isolation between transmitter and receiver path. This effect is called self-mixing and leads to a DC signal that depends on the carrier frequency. Using FMCW, these signals move and may overdrive the 2<sup>nd</sup> stage (x\_AC outputs) of the IF amp under certain circumstances.

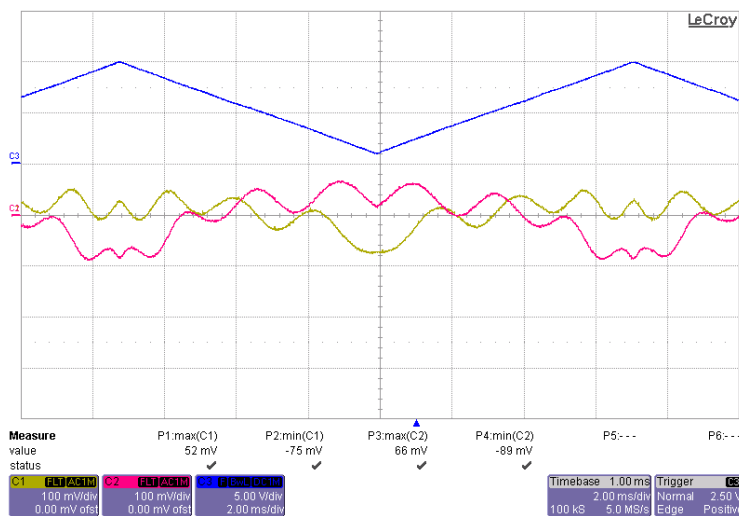

#### Example showing a single target:

Triangle VCO Amplitude: 8Vpp  
 Triangle period  $T_M = 14\text{ms}$ .  
 Modulation depth  $f_M = 160\text{MHz}$   
 IF output freq.  $f_b = 450\text{Hz}$

I\_AC and Q\_AC outputs show a low frequency caused by local carrier feedthrough.

The superposed higher frequency  $f_b$  is often called beat frequency, caused by a target at a distance of about 3m.

Fig. 5: x\_AC Output FMCW signals with triangle VCO and  $df = 160\text{MHz}$

### Distance calculation

$$R = \frac{c_0}{2} \cdot \frac{f_b}{f_M} \cdot \frac{T_M}{2} = 3\text{m approx}$$

For legend refer to Fig. 5

$R$  Range, distance to target

$c_0$  Speed of light ( $3 \cdot 10^8$  m/s)

Please contact RFbeam Microwave GmbH for more informations on FMCW and also on FSK applications.

### I\_AC and Q\_AC High Gain Outputs

These outputs provide high gain/low noise signals generated by doppler effects or FMCW. They directly can drive ADC input stages of microprocessors or DSPs. Even with 10Bit of resolution only, sensitive and relatively long range Doppler detections are possible. The outputs cover a frequency range of 40Hz ... 15kHz.

However, these outputs may saturate and clip because of too high input signals. In these cases you may use the x\_DC outputs described below.

### I\_DC and Q\_DC Low Gain Outputs

The low gain DC outputs (I\_DC and Q\_DC) hardly enter into a saturation state and may be used in cases, where the high gain outputs (I\_AC and Q\_AC) are clipped because of high input signals. Saturation and clipping typically arise in conjunction with FMCW and may be caused by objects nearby the sensor, non-compensated radoms etc.

These outputs carry more signal information than the x\_AC outputs because of their bandwidth ranging from DC to 500kHz. Using ADCs with resolutions of 12Bits and more and processing with DSP processors allow versatile and flexible radar applications.

### Rapid Sleep Wakeup (RSW)

RFbeam's unique rapid sleep wakeup feature allows power savings of more than 90% during 'silent' periods. The module may be used in a relaxed sampling mode as long as no movements are detected. RSW also helps saving power, if not the full IF bandwidth of 15kHz is needed.

In battery operated equipment such as traffic control, RSW may significantly lower battery and equipment volume and cost.

### RSW in Action

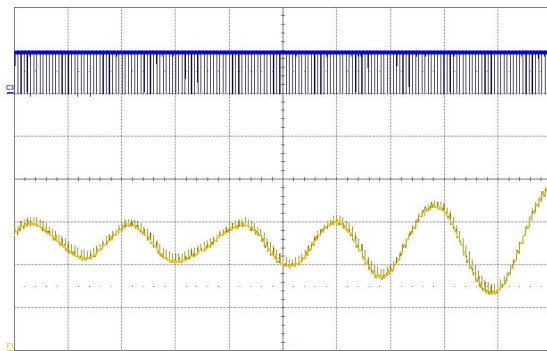

This graph shows the sampling signal at pin */Enable* and a resulting output signal at an *x\_AC pin* caused by an approaching object.

This signal may be processed 'as is' or used as trigger to start continuous acquisition.

If RSW mode is used only to detect any movement, aliasing effects are not important (i.e. undersampling is useful).

By choosing a sampling frequency, aliasing must be taken into account, if frequency measurements are intended.

Fig. 6: Sampled Doppler signal at x\_AC outputs

### RSW principle

RSW combines switching of the RF oscillator and sample&hold of the mixer signals (please refer to Fig. 1: K-MC1 Blockdiagram). During sleep mode (pin */ENABLE* = high), only the amplifiers stay switched on to hold the output voltage and coupling capacitor charges. This assures minimum peaks at the outputs when returning to the active state.

Nevertheless, we have to take some important effects into account. An important effect is charge injection, caused by the digital control signal.

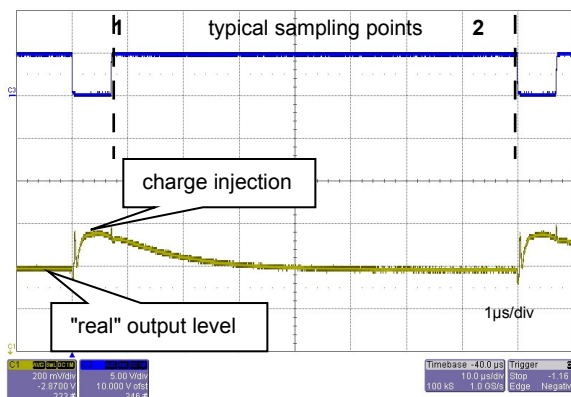

*/ENABLE* signal with  $t_{on} = 7\mu s$ .

*x\_AC* output signal recovers after  $80\mu s$  approx.

Fig. 7: *x\_AC* output is influenced by charge injection caused by switching signal

### Sampling sequence

To simplify signal processing sequence, output sampling may be done immediately after /ENABLE goes high (1) or before next /ENABLE (2).

Both methods have their advantages and disadvantages:

- Sampling point (1) contains a constant overshoot, i.e. sampled output signal becomes shifted by a constant DC component. There is no loss of sensitivity.
- Sampling point (2) corresponds to the real mixer output, as long as sleep time is short enough. But with longer off times, signal amplitude decreases.

As a rule of thumb: with a repeat frequency of 1kHz (duty cycle of  $7\mu\text{s}/1\text{ms} = 0.7\%$ ) amplitude loss is 3dB approx. This situation is shown in the figure below.

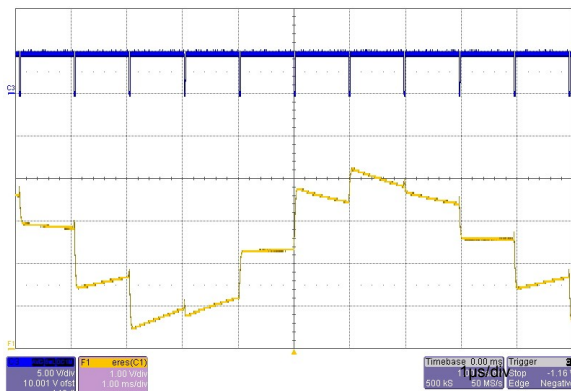

Sampling signal ( $t_c = 1\text{ms}$ ,  $t_{\text{on}} = 7\mu\text{s}$ )

Output signal decreases during the off-period with a timeconstant of 4.8ms approx.

**Fig. 8: x\_AC output amplitude decreases during sleep time.**

### Sensitivity and Maximum Range

The values indicated here are intended to give you a 'feeling' of the attainable detection range with this module. It is not possible to define an exact RCS (radar cross section) value of real objects because reflectivity depends on many parameters. The RCS variations however influence the maximum range only by  $\sqrt[4]{\sigma}$ .

Maximum range for Doppler movement depends mainly on:

- Module sensitivity	S:	-141dBc (@1kHz IF Bandwidth)
- Carrier frequency	f <sub>0</sub> :	24.125GHz
- Radar cross section RCS ("reflectivity") of the object	σ <sup>1)</sup> :	1m <sup>2</sup> approx. for a moving person >50m <sup>2</sup> for a moving car

note <sup>1)</sup> RCS indications are very inaccurate and may vary by factors of 10 and more.

The famous "Radar Equation" may be reduced for our K-band module to the following relation:

$$r = 0.0167 \cdot 10^{\frac{-s}{40}} \cdot \sqrt[4]{\sigma}$$

Using this formula, you get an indicative detection range of

- 56 meters for a moving person
- > 150 meters for a moving car

Please note, that range values also highly depend on the performance of signal processing, environment conditions (i.e. rain, fog), housing of the module and other factors.

### Datasheet Revision History

Version	Date	Changes
1.0	08-Aug-2007	initial release
1.1	29-Oct-2008	Replaced Fig. 4: Mechanical dimensions Added chapter counting instruction
1.2	09-Nov-2009	Operating temperature corrected to +80°C
1.3	15-Dec-2009	VCO sensitivity corrected to 22MHz/V
2.0	13-July-2011	Adapted to new hardware Revision G, valid from lot # L1114

RFbeam does not assume any responsibility for use of any circuitry described, no circuit patent licenses are implied and RFbeam reserves the right at any time without notice to change said circuitry and specifications.